



■ Features :

- Universal AC input / Full range
- Built-in 5V/0.3A, 12V/0.8A auxiliary power
- Built-in active PFC function, PF>0.97
- Protections: Short circuit / Overload / Over voltage / Over temperature
- Forced air cooling by built-in DC fan with fan speed control
- Output voltage can be trimmed between 40~115% of the rated output voltage
- High Power density 21.4W/inch³
- 1U low profile 41mm
- Active current sharing up to 8000W(3+1)
- Built-in remote ON-OFF control
- Built-in remote sense function
- DC OK signal, OTP alarm signal
- 5 years warranty



SPECIFICATION

MODEL	RSP-2000-12		RSP-2000-24		RSP-2000-48		
OUTPUT	DC VOLTAGE	12V		24V		48V	
	RATED CURRENT	100A		80A		42A	
	CURRENT RANGE	0 ~ 100A		0 ~ 80A		0 ~ 42A	
	RATED POWER	1200W		1920W		2016W	
	RIPPLE & NOISE (max.) Note.2	150mVp-p		200mVp-p		300mVp-p	
	VOLTAGE ADJ. RANGE	10.5 ~ 14V		21 ~ 28V		42 ~ 56V	
	VOLTAGE TOLERANCE Note.3	±2.0%		±1.0%		±1.0%	
	LINE REGULATION	±1.0%		±0.5%		±0.5%	
	LOAD REGULATION	±1.0%		±0.5%		±0.5%	
	SETUP, RISE TIME	1500ms, 60ms/230VAC at full load					
HOLD UP TIME (Typ.)	16ms/230VAC at 75% load		10ms/230VAC at full load				
INPUT	VOLTAGE RANGE Note.5	90 ~ 264VAC		127 ~ 370VDC			
	FREQUENCY RANGE	47 ~ 63Hz					
	POWER FACTOR (Typ.)	0.97/230VAC at full load					
	EFFICIENCY (Typ.)	87%		90.5%		92%	
	AC CURRENT (Typ.) Note.5	13A/115VAC 7A/230VAC		16A/115VAC 10A/230VAC		16A/115VAC 10A/230VAC	
	INRUSH CURRENT (Typ.)	COLD START 50A					
LEAKAGE CURRENT	<2mA / 240VAC						
PROTECTION	OVERLOAD	105 ~ 125% rated output power Protection type : Constant current limiting, unit will shut down o/p voltage after 5 sec. re-power on to recover					
	OVER VOLTAGE	14.7 ~ 17.5V		29.5 ~ 35V		57.6 ~ 67.2V	
	OVER TEMPERATURE	Shut down o/p voltage, recovers automatically after temperature goes down					
FUNCTION	AUXILIARY POWER	5V @ 0.3A, 12V @ 0.8A					
	REMOTE ON/OFF CONTROL	By electrical signal or dry contact Power ON:open Power OFF:short, refer to function manual					
	REMOTE SENSE	Compensate voltage drop on the load wiring up to 0.5V, refer to function manual					
	DC OK SIGNAL	The isolated TTL signal out, refer to function manual					
	OUTPUT VOLTAGE TRIM	Adjustment of output voltage, possible between 40 ~ 115% of rated output, refer to function manual					
ENVIRONMENT	WORKING TEMP.	-35 ~ +70°C (Refer to "Derating Curve")					
	WORKING HUMIDITY	20 ~ 90% RH non-condensing					
	STORAGE TEMP., HUMIDITY	-40 ~ +85°C, 10 ~ 95% RH					
	TEMP. COEFFICIENT	±0.03%/°C (0 ~ 50°C)					
	VIBRATION	10 ~ 500Hz, 2G 10min./1cycle, 60min. each along X, Y, Z axes					
SAFETY & EMC (Note 4)	SAFETY STANDARDS	UL60950-1, TUV EN60950-1 approved					
	WITHSTAND VOLTAGE	I/P-O/P:3KVAC I/P-FG:2KVAC O/P-FG:0.5KVAC					
	ISOLATION RESISTANCE	I/P-O/P, I/P-FG, O/P-FG:100M Ohms / 500VDC / 25°C / 70% RH					
	EMC EMISSION	Compliance to EN55022 (CISPR22) Conduction Class B, Radiation Class A ; EN61000-3-2,-3					
	EMC IMMUNITY	Compliance to EN61000-4-2,3,4,5,6,8,11, EN61000-6-2 (EN50082-2), heavy industry level, criteria A					
OTHERS	MTBF	46.3K hrs min. MIL-HDBK-217F (25°C)					
	DIMENSION	295*127*41mm (L*W*H)					
	PACKING	1.95Kg; 6pcs/12.7Kg/1.15CUFT					
NOTE	<ol style="list-style-type: none"> 1. All parameters NOT specially mentioned are measured at 230VAC input, rated load and 25°C of ambient temperature. 2. Ripple & noise are measured at 20MHz of bandwidth by using a 12" twisted pair-wire terminated with a 0.1uf & 47uf parallel capacitor. 3. Tolerance : includes set up tolerance, line regulation and load regulation. 4. The power supply is considered a component which will be installed into a final equipment. The final equipment must be re-confirmed that it still meets EMC directives. 5. Derating may be needed under low input voltages. Please check the derating curve for more details. 6. Under parallel operation ripple of the output voltage may be higher than the SPEC at light load condition. It will go back to normal ripple level once the output load is more than 5%. 						

Mechanical Specification

Case No. 952D Unit:mm

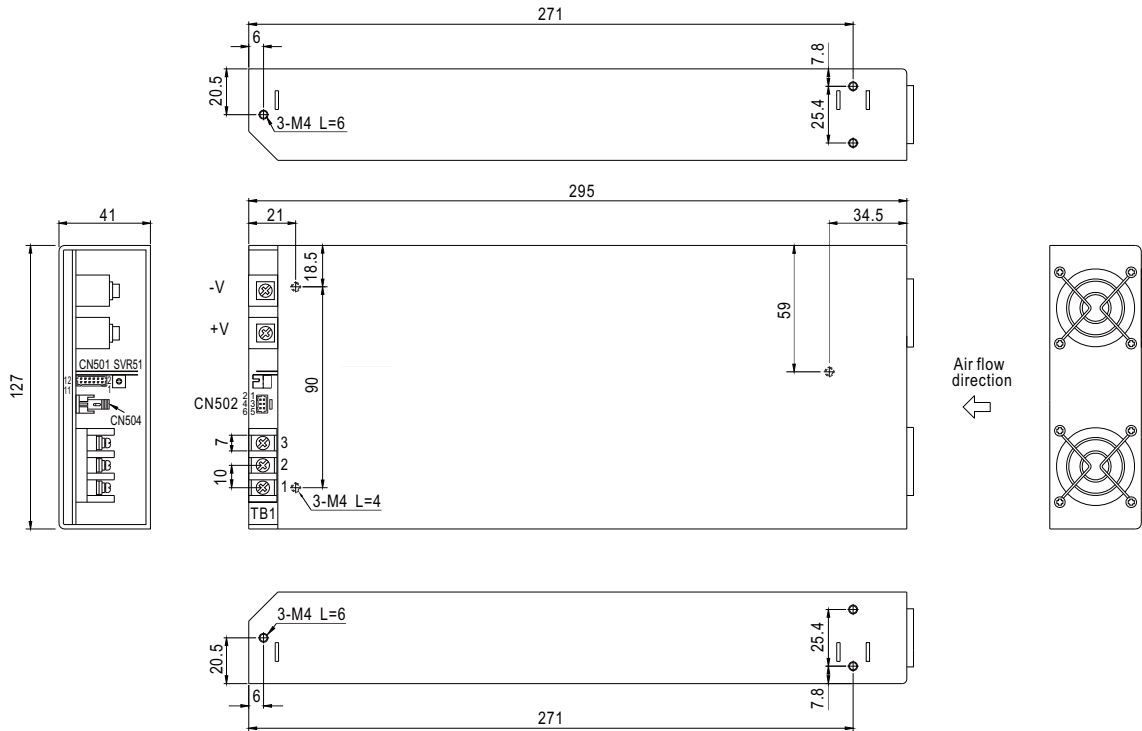

AC Input Terminal Pin No. Assignment

Pin No.	Assignment
1	AC/N
2	AC/L
3	FG \perp

Control Pin No. Assignment (CN501) : HRS DF11-12DP-2DS or equivalent

Pin No.	Assignment	Pin No.	Assignment	Pin No.	Assignment	Mating Housing	Terminal
1	+S	5	DC-OK	9	GND-AUX	HRS DF11-12DS or equivalent	HRS DF11-**SC or equivalent
2	-S	6	T-ALARM	10	GND-AUX		
3	PV	7	ON/OFF	11	+5V-AUX		
4	GND	8	GND-AUX	12	+12V-AUX		

Control Pin No. Assignment(CN502) : HRS DF11-6DP-2DSA or equivalent

Pin No.	Assignment	Mating Housing	Terminal
1,2	DA	HRS DF11-6DS or equivalent	HRS DF11-**SC or equivalent
3,4	DB		
5,6	GND		

Block Diagram

PFC fosc : 110KHz
PWM fosc : 90KHz

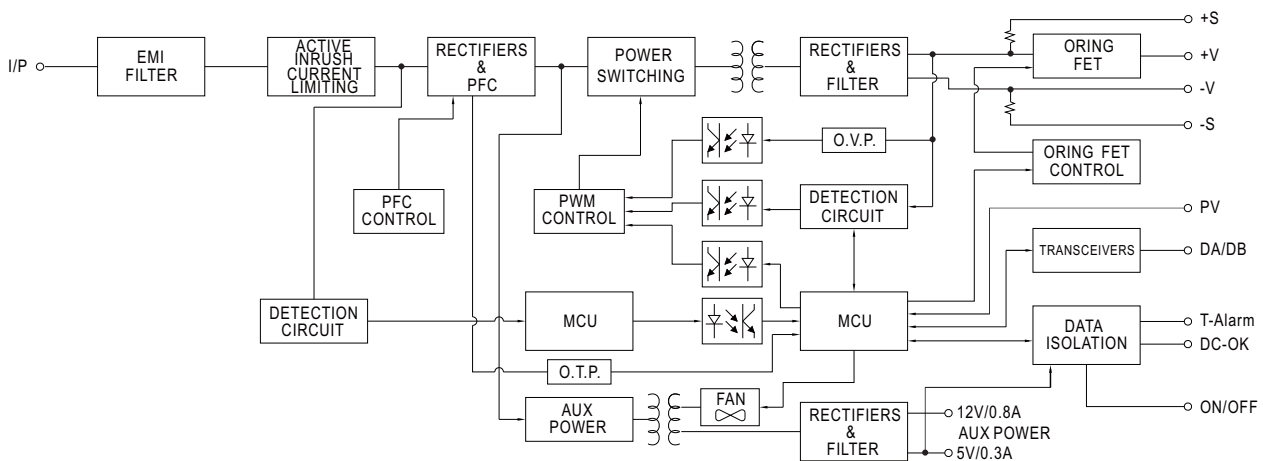

■ Function Description of CN501

Pin No.	Function	Description
1	+S	Positive sensing. The +S signal should be connected to the positive terminal of the load. The +S and -S leads should be twisted in pair to minimize noise pick-up effect. The maximum line drop compensation is 0.5V.
2	-S	Negative sensing. The -S signal should be connected to the negative terminal of the load. The -S and +S leads should be twisted in pair to minimize noise pick-up effect. The maximum line drop compensation is 0.5V.
3	PV	Connection for output voltage trimming. The voltage can be trimmed within its defined range. (Note.1)
4	GND	This pin connect to the negative terminal(-V).
5	DC-OK	High (4.5 ~ 5.5V) : When the $V_{out} \leq 80\% \pm 6\%$. Low (0 ~ 0.5V) : When $V_{out} \geq 80\% \pm 6\%$. The maximum sourcing current is 10mA and only for output. (Note.2)
6	T-ALARM	High (4.5 ~ 5.5V) : When the internal temperature (TSW1 or TSW2 open) exceeds the limit of temperature alarm. Low (0 ~ 0.5V) : When the internal temperature (TSW1 or TSW2 short) under the limit temperature. The maximum sourcing current is 10mA and only for output. (Note.2)
7	ON/OFF	The unit can turn the output on and off by electrical signal or dry contact between ON/OFF and +5V-AUX. (Note.2) Short (4.5 ~ 5.5V) : Power OFF ; Open (0 ~ 0.5V) : Power ON ; The maximum input voltage is 5.5V.
8,9,10	GND-AUX	Auxiliary voltage output GND. The signal return is isolated from the output terminals (+V & -V).
11	+5V-AUX	Auxiliary voltage output, 4.5~5.5V, referenced to GND-AUX (pin). The maximum load current is 0.3A. This output has the built-in "Oring diodes" and is not controlled by the remote ON/OFF control.
12	+12V-AUX	Auxiliary voltage output, 10.6~13.2V, referenced to GND-AUX (pin). The maximum load current is 0.8A. This output has the built-in "Oring diodes" and is not controlled by the remote ON/OFF control.

Note1: Non-isolated signal, referenced to the output terminals (-V).

Note2: Isolated signal, referenced to GND-AUX.

■ Function Description of CN502

Pin No.	Function	Description
1,2	DA	Differential digital signal for parallel control.
3,4	DB	Differential digital signal for parallel control.
5,6	GND	These pins connect to the negative terminal (-V).

■ Function Description of CN504

Pin No.	Function	Description
1,2	Terminal resistance	CN504 is the selector of terminal resistor that is designed for DA/DB signals and parallel control function.

■ Derating Curve

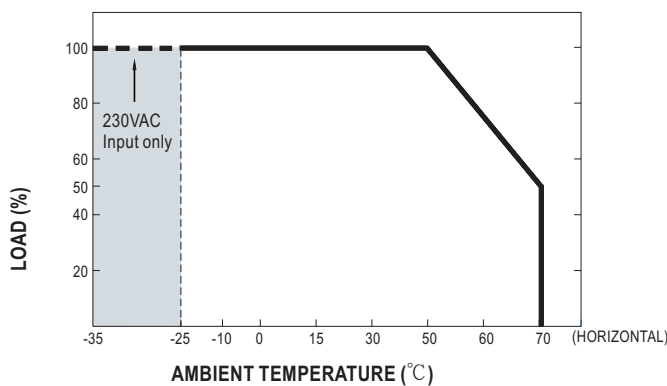

■ Static Characteristics

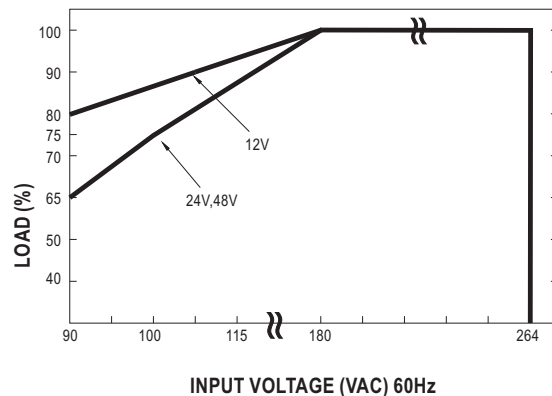

■ EFFICIENCY vs LOAD (48V Model)

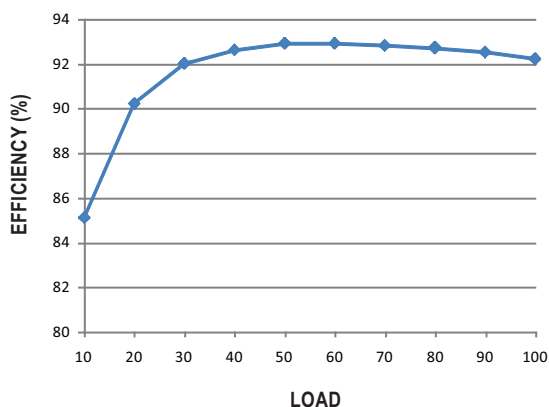

■ DERATING LOAD(%) VS INPUT VOLTAGE

INPUT / VOLTAGE	180VAC	115VAC	100VAC	90VAC
MODEL				
RSP-2000-12	100%	95%	90%	80%
RSP-2000-24	100%	80%	75%	65%
RSP-2000-48	100%	80%	75%	65%

Function Manual

1. Remote ON/OFF Control

The PSU can be turned ON/OFF together or separately by using the "Remote ON/OFF" function.

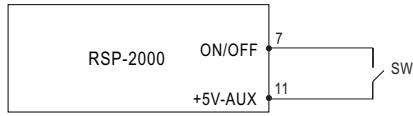

Between ON/OFF and +5V-AUX	PSU Output
SW Open	ON
SW Short	OFF

2. Remote Sense

The remote sense compensates voltage drop on the load wiring up to 0.5V.

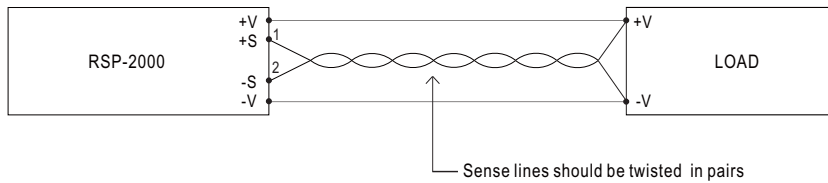

3. Output Voltage Trimming

(1) Output voltage can be trimmed between 40~115% of its rated value by the following method.

(2) +S & +V, -S & -V also need to be connected on CN501.

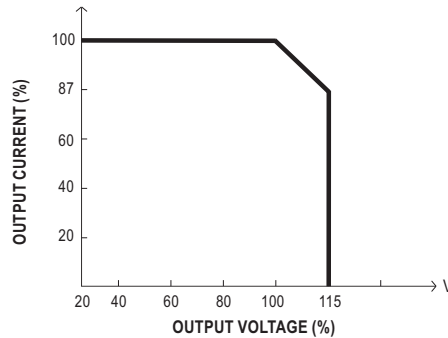
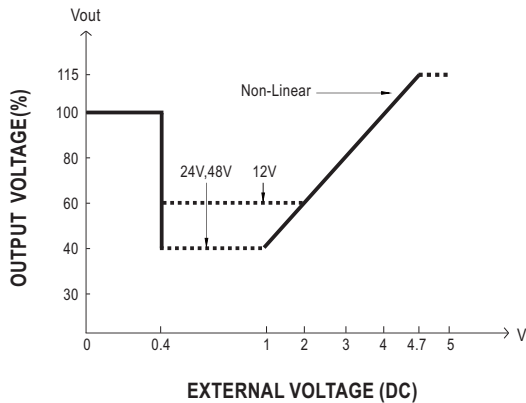
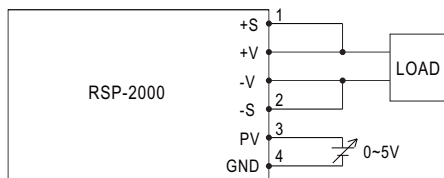

MODEL	PV / VOLTAGE					
	<0.4V	1V	2V	3V	4V	4.7V
RSP-2000-12	100%	60%	60%	80%	100%	115%
RSP-2000-24	100%	40%	60%	80%	100%	115%
RSP-2000-48	100%	40%	60%	80%	100%	115%

4. Front Panel Indicators & Corresponding Signal at Function Pins

Function	LED	Description	* Signal	PSU Output
DC-OK	GREEN	When output voltage $\geq 80\% \pm 5\%$ of V_o rated.	0 ~ 0.5V	ON
DC-NG	RED	When output voltage $\leq 80\% \pm 5\%$ of V_o rated.	4.5 ~ 5.5V	ON
T-OK	GREEN	When the internal temperature (TSW1 & TSW2 short) is within safe limit	0 ~ 0.5V	ON
T-ALARM	RED	When the internal temperature (TSW1 or TSW2 open) exceeds the limit of temperature alarm	4.5 ~ 5.5V	OFF

*Signal between function pin and "GND-AUX".

5.Current Sharing with Remote Sensing

RSP-2000 has the built-in active current sharing function and can be connected in parallel to provide higher output power :

- (1)Parallel operation is available by connecting the units shown as below.
(DA,DB and GND are connected mutually in parallel).
- (2)Difference of output voltages among parallel units should be less than 0.2V.
- (3)The total output current must not exceed the value determined by the following equation.
(output current at parallel operation)=(Rated current per unit)×(Number of unit)×0.9
- (4)In parallel operation 4 units is the maximum, please consult the manufacturer for applications of more connecting in parallel.
- (5)The power supplies should be paralleled using short and large diameter wiring and then connected to the load.
- (6) Under parallel operation, the minimum output load should be greater than 5% of total output load.
- (7) Under parallel operation ripple of the output voltage may be higher than the SPEC at light load condition. It will go back to normal ripple level once the output load is more than 5%.
- (8) CN502/CN504 Function pin connection

Parallel	PSU1		PSU2		PSU3		PSU4	
	CN502	CN504	CN502	CN504	CN502	CN504	CN502	CN504
1 unit	X	V	—	—	—	—	—	—
2 unit	V	V	V	V	—	—	—	—
3 unit	V	V	V	X	V	V	—	—
4 unit	V	V	V	X	V	X	V	V

※ V is CN502/CN504 connected to plug pin, X is CN502/CN504 not connected to plug pin.

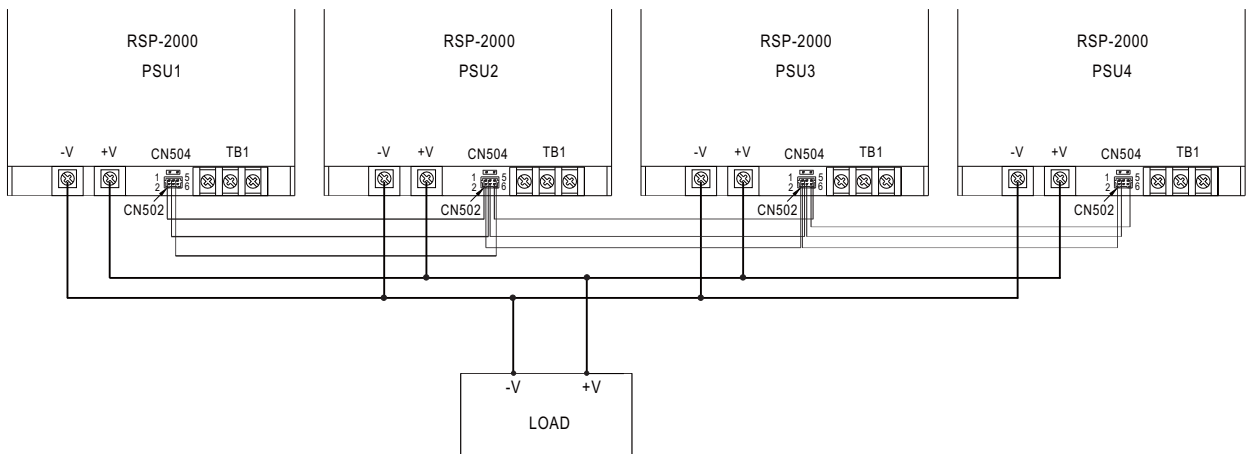
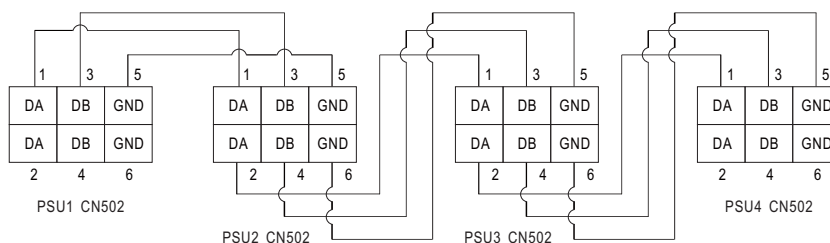

Fig 6.1



If the lines of CN502 are too long, they should be twisted in pairs to avoid the noise.